

# Technical data sheet

## Product features



### Cutter 8l triphase

<b>Model</b>	<b>SAP Code</b>	00013740
--------------	-----------------	----------



- Material: Stainless steel
- Volume capacity of the container [l]: 8.00
- Control type: Mechanical 24 V: Start, stop, puls
- Safety cover: polycarbonate with squeegee
- Number of revolutions / min: 1400
- Start /stop: Yes
- Safety element: lid microswitch
- Standard equipment for device: smooth knife included in the price of the machine
- Additional information: possibility to order perforated and serrated knife

<b>SAP Code</b>	00013740	<b>Power electric [kW]</b>	1.140
<b>Net Width [mm]</b>	260	<b>Loading</b>	400 V / 3N - 50 Hz
<b>Net Depth [mm]</b>	290	<b>Number of revolutions / min</b>	1400
<b>Net Height [mm]</b>	560	<b>Volume capacity of the container [l]</b>	8.00
<b>Net Weight [kg]</b>	24.50		

# Technical data sheet

Technical drawing



Cutter 8l triphase

Model

SAP Code

00013740

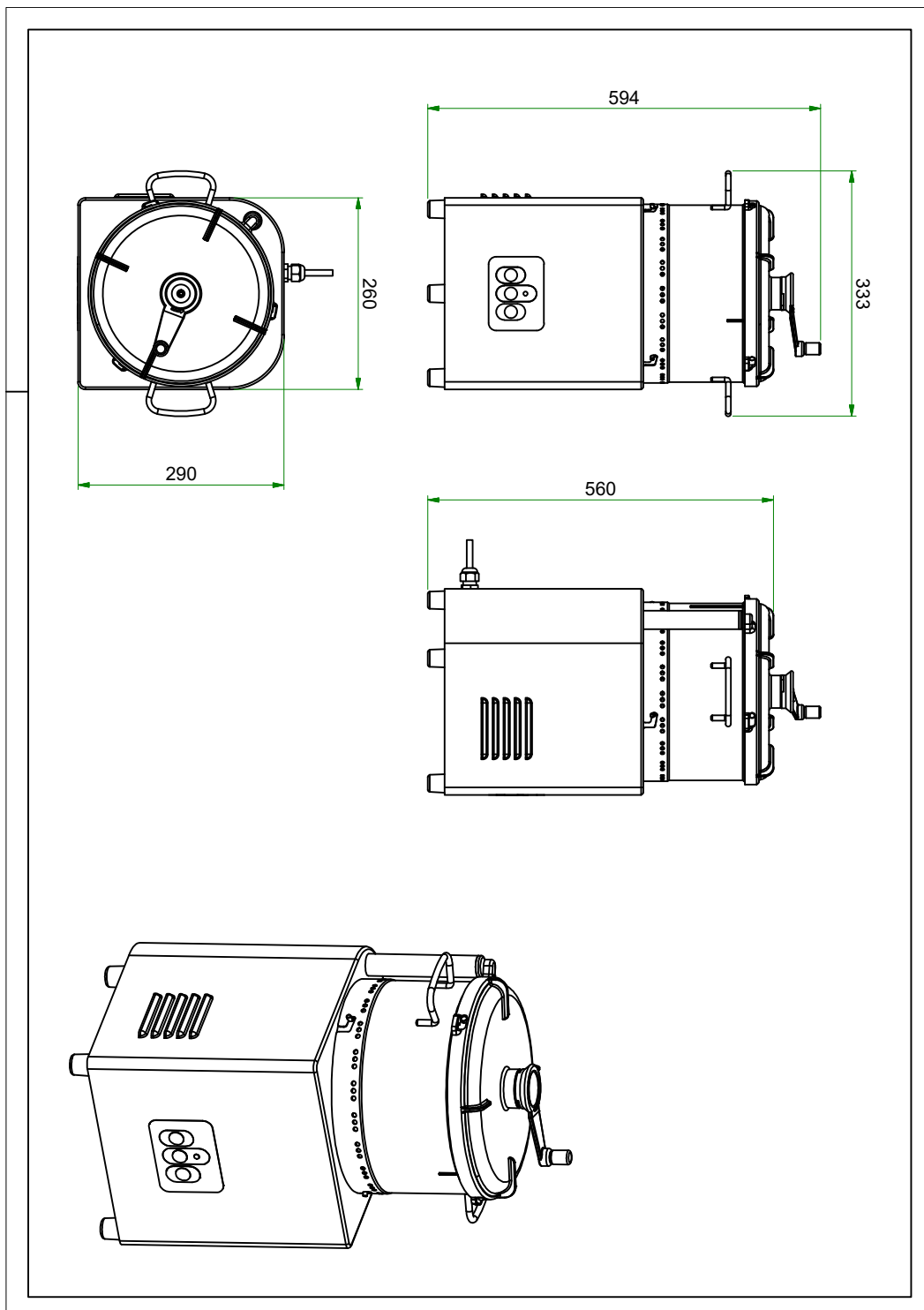

# Technical data sheet

## Product benefits



### Cutter 8l triphase

Model

SAP Code

00013740

1

#### All-stainless design

- robustness  
purity
- long service life
  - very easy to clean

2

#### Polycarbonate lid

- transparent
- thanks to the transparent lid, I can easily follow the processing process, I don't waste time opening and peeking

3

#### Safety microswitches

- safe operations
- the machine cannot be started without perfect closure, thus protecting the health of the workers

4

#### Three knives to choose from

- variability of use for chopping, whipping and kneading
- variability of use saves the cost of purchasing additional machines

5

#### A trowel

- there will be 100% whipping/whipping/cutting...
- no waste, easy to wipe off quickly, no lumps in the final product

6

#### Pulsed and sustained running

- the operator has the option of choosing the coarseness of chopping/beating rate
- variability in food processing allows the highest quality of food to be achieved e.g. chopped onions do not turn bitter when pulse chopped

# Technical data sheet

Technical parameters



## Cutter 8l triphase

Model

SAP Code

00013740

### 1. SAP Code:

00013740

### 2. Net Width [mm]:

260

### 3. Net Depth [mm]:

290

### 4. Net Height [mm]:

560

### 5. Net Weight [kg]:

24.50

### 6. Gross Width [mm]:

340

### 7. Gross depth [mm]:

385

### 8. Gross Height [mm]:

755

### 9. Gross Weight [kg]:

26.50

### 10. Device type:

Electric unit

### 11. Material:

Stainless steel

### 12. Power electric [kW]:

1.140

### 13. Loading:

400 V / 3N - 50 Hz

### 14. Volume capacity of the container [l]:

8,00

### 15. Control type:

Mechanical 24 V: Start, stop, puls

### 16. Safety cover:

polycarbonate with squeegee

### 17. Safety element:

lid microswitch

### 18. Number of revolutions / min:

1400

### 19. Safety Microswitch:

Yes

### 20. Start /stop:

Yes

### 21. Standard equipment for device:

smooth knife included in the price of the machine

### 22. Additional information:

possibility to order perforated and serrated knife

### 23. Unmountable bowl:

Yes

### 24. Suitable operations:

Chopping, whipping and kneading

### 25. Cross-section of conductors CU [mm<sup>2</sup>]:

0,5

- Výkon (kW): 2,4-3,3 (230 V)